



GORGE TILLICUM

Neighbourhood

NEWS



Your community association has been examining walking as a transportation choice for our neighbourhood.

or to save 15 percent at the Il Greco pickup window, we jump in our cars. So much for the 15 percent savings, you just spent it to get there.

Where we have developed sidewalks, there are many problems with design and function. Why would we expect someone who needs to use a wheelchair or scooter to use a sidewalk that has a ramp that aims out into the traffic lanes? How can they even use this ramp?

Your community association has been examining walking as a transportation choice for our neighbourhood.

Along Gorge Road there are many of our senior citizens living in apartments and condos. Some have difficulty walking quickly and on some intersections they are exposed to the traffic lane much longer than necessary because the corner has been designed to make it easier for cars. Why is that?. If the design is more like the illustration on page 4, the time that a pedestrian is exposed to automobile traffic would be reduced by 8 feet and the vehicle would enter the side street at an appropriate speed for a pedestrian zone.

Walking, design and function

Those of us that have chosen to live in the Gorge Tillicum neighbourhood are so lucky. Anytime we want we can go for a walk. We walk our dogs along the

Gorge Walkway or in Cuthbert Holmes Park all the time. Our neighbourhood is full of great walking opportunities with more being created all of the time. However, when we look to walking as a way to get somewhere, such as going to pick up a few groceries, there are some glaring deficiencies.

In our neighbourhood, there are very few sidewalks in place. This is mostly because Saanich in the early days did not see the need to build sidewalks as part of the urban transportation infrastructure. "We will save the taxpayers money" was the cry of the day. Unfortunately, the result has cost the taxpayer dearly because we ended up encouraging automobile based developments which put the additional costs of owning expensive vehicles on the home owner. So rather than walking to the video store, to the drug store

Inside This Issue

- 1 Walking, design and function
- 2 Bell Walk for Kids
- 3 Saanich Council
- 3 Admirals Road
- 3 Dessert & Discussion
- 3 AGM Announcement
- 4 The Green Space
- 6 Waterways - Green Roads
- 7 Local Heroes
- 7 West Gorge Transportation Committee Report
- 8 G.R. Pearkes Recreation Centre
- 8 Gorge Canada Day Picnic, Of Days Gone By and Transitions



**Gorge-Tillicum
Neighbourhood News**

We welcome comments—please let us know what you think of your newsletter!

Editor:

Melinda Harris 383-5335
melinda@gowestgroup.com

Article Coordinators:

Paul Gerrard 386-2745
pgerrard@pacificcoast.net
General - Rob Wickson
812-9164 wickson@telus.net
GreenSpace - Julia Menard
julia@makeandbelieve.com
Local Heroes - Harry Lewis
384-8460 h.lewis@telus.net

Published Quarterly:

Winter (Jan/Feb)
Spring (April)
Summer (June/July)
Fall (Oct/Nov)

Unsolicited Articles Welcome.

The deadline for submissions and advertising for the next issue is June 4th

Graphic Design:

GoWest Group
www.gowestgroup.com

Advertising Inquiries:

Arden Little 360-2474 or
Ray Farmer 382-1122

Distribution:

All 4000 copies of this newsletter are delivered by volunteers and we could always use more help. Please contact Ray Farmer 382-1122.

Do you have experience maintaining websites? Please contact: Ray Farmer 382-1122

**Gorge Tillicum
Community Association
Membership**

GTCA memberships run Jan. to Dec. at a cost of \$5.00 for individuals and \$25.00 for businesses.

Name: _____

Address: _____

Phone: _____

Mail to: GTCA, PO Box 44152,
2947 Tillicum Rd., Victoria, BC V9A 2A0.

**Bell
WALK FOR KIDS**



KIDS HELP PHONE

IN SUPPORT OF KIDS HELP PHONE

The excitement is building in anticipation of the third annual Bell Walk for Kids in support of Kids Help Phone taking place in more than 35 communities across Canada. This event is Kids Help Phone's number one fundraising event that they anticipate will raise over \$1.5 million dollars to help provide the immediate support that troubled and abused kids need and deserve. What's exciting for us is that Victoria's event has been moved right here to the Gorge/Tillicum neighbourhood!

Kids Help Phone is Canada's only national, toll-free, 24-hour phone counselling, referral, and internet service providing immediate and professional counselling support for young people. Kids Help Phone takes approximately 1,000 calls each day from children, some as young as 4, others perhaps 20. In 2002 the website received almost 460,000 visits. Kids call or post questions about a range of issues including physical, sexual and emotional abuse, addictions, violence and suicide. Affiliated Parent Help Line helps kids by helping parents with their parenting concerns, from coping with stress to violence and drug addiction. All calls

made to Kids Help Phone and Parent help Line are free, completely anonymous, and confidential.

Lynn is 17. She ran away from home last year and is living with her boyfriend. He hits her. Like her father did. After he was asleep last night, Lynn decided to leave him. A Kids Help Phone counsellor helped her find a local shelter immediately.

Ethan is 12. Last month his dad died. His mother, brother and sister just cannot cope with it. None of his friends understand. He logged-on to the Kids Help Phone website because he really just needed someone to talk to. On his terms and his time.

The walk starts at 10:00 am on Sunday, May 2nd at Silvercity Tillicum. The route, through Cuthbert Holmes Park down Admirals, Gorge and back up Tillicum Rd is approximately 5 km in length and is suitable for everyone. This is a great opportunity for all of us to spend time with our own families and friends in support of an important cause. Join us, we need your help. Registration forms are available at Silvercity, any Bank of Montreal or Bell Mobility location.

For more information, visit
www.bellwalkforkids.ca.

Gorge Tillicum Community Association www.gorgetillicum.ca

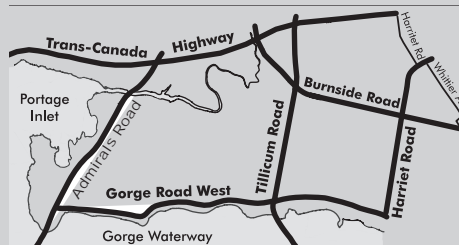

**GTCA Board of Directors
2003/2004**

President: Paul Gerrard 386-2745
pgerrard@pacificcoast.net
Vice-president: Ed Lyons 479-8030
edlyons@telus.net
Secretary: Christine Helmink 385-3388
chelmink@hotmail.com

Treasurer: Rob Wickson 812-9164
wickson@telus.net
Membership: John Hoole 386-7458
jhoole@spca.bc.ca
Susan Dunlop 360-8454
susan@brassandwoodwind.ca
Past President: Harry Lewis 384-8460
h.lewis@telus.net
Arden Little 360-2474
ardenlittle@shaw.ca
Ray Farmer 382-1122
jpullman@shaw.ca
Scott Murdoch 598-5229
smurdoch@shaw.ca
Bob June 381-0848
The Board meets the first Thursday of each month, September to June, at Pearkes Recreation Centre. All members are welcome to attend!

Local Heroes Jack Day



Our local hero for the Spring edition of Neighbourhood News seems entirely appropriate. **Jack Day** is a gardener for Saanich who has been working on the Gorge Waterway Park for twenty years, and during that time he has gained many friends and admirers. Not only does Jack love the park and the plants he's responsible for, but also the people who stop for a chat while he's at work. He describes the locals he meets regularly "like a club", and how much he appreciates the support, interest and care shown by those who frequent the park. And it's not only Gorge locals who appreciate Jack's work as many people from other parts of town, tourists and even 'snowbirds' are amongst his visitors at different times.

The Waterway Park is a jewel in the fabulous array of Saanich parks and takes a high priority for maintenance so Jack is to be found there most days of the week. He has a fairly free rein when it comes to the design decisions on perennials and annuals for the beds and this is his favourite part of the gardening job, where his skills are best put to use.

Jack now conducts 'Garden Walks' that are very popular and more information on these can be found in the upcoming Parks and Recreation program.

We wish Jack many more happy seasons on the Gorge with his "club" and offer our thanks to the Local Hero who tends our 'front garden' with so much care. — By Harry Lewis

Do you know a local hero? Please contact Harry Lewis 384-8460

West Gorge Transportation Committee Report

We are methodically winding our way through the process of obtaining the information needed to pinpoint the major traffic problems in the West Gorge area, with a view to applying to Saanich Council later in the year for appropriate traffic calming measures to alleviate these problems- assuming that it is the will of the community that we do so.

One of the major steps in this process is the transportation survey, which is now in the course of being delivered to every home in the area- some of you will receive it with this Newsletter. Please do take the five minutes or so needed to complete it and send it back to us as soon as you can- this is your chance to help us understand your local traffic concerns, and the stronger the response we get, the better leverage we have with Saanich.

Once the survey responses have been collated and put with the other statistical information we are collecting, such as accident statistics, traffic counts and speed board readings, we will be in a position to hold a public forum to communicate the results and seek your input as to how best to counter the various problems that will be highlighted. — by John Hoole

If you have any questions, or if you would like to join the committee or help in any way, please contact

Donna Roth 388-7039
donna.roth@shaw.ca or

John Hoole 386-7458
jhoole@sca.bc.ca

Top Shelf Bookkeeping Ltd.

EFILE service
from **\$35 plus GST**

HOURS Feb 23–April 30

Monday to Wednesday	9AM–6PM
Thursdays	9AM–8PM
Fridays	9AM–4PM
Saturdays	10AM–4PM

Interac - Visa - MasterCard - Amex
432 Obed Avenue, Victoria, BC V9A 1K5
Tel: 250-388-9423 Fax: 250-361-9424
Serving this community since 1994



Susan Brice, MLA

Saanich South
200-3939 Quadra Street,
Victoria, BC, V8X 1J5
ph:952-4418 fax:952-4566
susan.brice.mla@leg.bc.ca
www.susanbricemla.bc.ca



Waterways – Green Roads

Roads consume a large area of our neighbourhood. From an environmental perspective they contribute to; 1) increased stormwater runoff, 2) water pollution, and 3) urban heat island effect (roads absorb heat from the sun and cause a local increase in temperature). From a community perspective, roads can reduce pedestrian movement (eg. Tillicum and Burnside Roads) and isolate neighbourhoods from each other. Traffic noise is increasing as more cars are on the roads and with more traffic comes more people cutting through our neighbourhood as a way to get downtown faster.

A conventional 2 lane road is typically 8.5 metres of asphalt with concrete curbs and gutters on both sides. During rainstorms, water cannot infiltrate the asphalt so it is shed to the side of the road. Runoff is carried by the curb and gutter to the nearest stormdrain. From there it enters the Gorge or Colquitz Creek with all of the pollutants that it picked up on the way. These roads are not places for people and are not sensitive to the environment. Let's face it. The conventional road is built for the car...

....not for people or the environment!



to green our neighbourhood. In addition the cost of a green road is considerable less than a conventional road. There is less maintenance and significantly more community value in a green road.

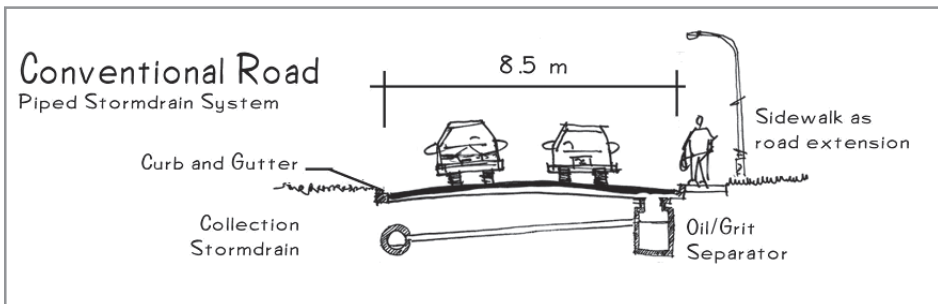

Which street would you rather live on? Which is safer, quieter, pedestrian friendly?

Next issue we will discuss surface drainage systems.

— Scott Murdoch

So the question is can we build a better road, one that works for the environment, pedestrians, and cars? Lucky for us the answer is YES. By simply narrowing roads to six metres we can reduce the amount of impervious surface by 30% while still allowing safe movement of vehicles. Most of our roads are narrow and we should work as a community to maintain these smaller roads. The fact is that wide roads encourage drivers to drive faster. Just look at the difference in speed between Tillicum Road and Dysart Road for example. Since the road is narrower we have more room for a planted boulevard and a chance

References

Road Diets by Walkable Communities Inc., Florida, USA.
www.walkable.org/download/rdiets.pdf

Walkable Communities, Inc. is a non-profit corporation, established in the state of Florida in 1996. It was organized for the express purposes of helping whole communities, whether they are large cities or small towns, become more walkable and pedestrian friendly.

University of British Columbia Sustainable Communities
www.sustainablecommunities.agsci.ubc.ca

Resource guide on sustainable community design including publications, research, and design projects.

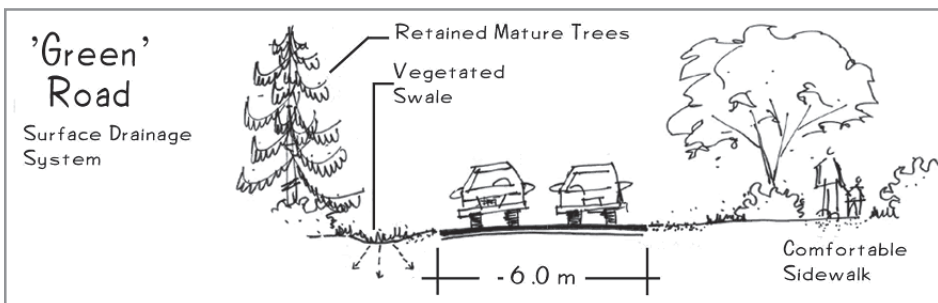

gorge VIDEO
 384-4330

101-300 Gorge Rd W
 Victoria, B.C.
 V9A 1M8.
 Reservations Accepted

Compliments of Jim, Leslie & Staff

one FREE video

5 FOR 5 FOR 5
5 BONUS REGULAR PRICES WITH 5 FOR 5 ONLY! SEE STORE FOR DETAILS.

1 FREE VIDEO WITH THIS AD

Custom Floral Design

Christine's Creations

For Valentine's Day ...for every day!

Fresh flowers and personal service guaranteed

216ñ0115
 3114 Harriet Road

www.flowerlady.ca

GARY McINNIS
 REAL ESTATE SALES

PEMBERTON

www.garymcinnis.com
 Telephone: 475-5728



Saanich Council

On Monday, March 8, 2004, at a committee of the whole meeting, Saanich Council voted to approve reserving the \$530,000 received from RioCan for the G.R.Pearkes Centre Branch Library project, including buildings, structures, site development and Bodega Road upgrading. A decision on the exact location of the proposed library was tabled until Saanich learns if their application for a provincial and federal infrastructure grant is successful.

Saanich Council also granted an early approval request for some 2004 Parks Capital Projects.

Craigflower Park is scheduled to have the playground and walkway completed, along with landscape improvements and minor upgrading of the washroom building in time for the Gorge Canada Day Picnic on July 1, 2004.

Work on the Centennial Trails initiative is beginning this year, and there are several opportunities to make significant improvements along the Colquitz River Trail. In co-operation with the Engineering Department, it is intended that the trail be made safer and more user friendly, including improved signs and neighbourhood maps.

Admirals Road

Saanich Engineering is used to getting complaints about their lack of service in various neighbourhoods, but they deserve a pat on the back for a recent project in our area that is almost completed.

Peter Sparanese and Daryl Yuen quickly produced a concept plan and fast-tracked our project.

Many of us were very concerned about the dangerous pedestrian environment on Admirals Road from the Colquitz bridge up to the Trans-Canada Hwy, and after contacting Peter Sparanese at Saanich, he and Daryl Yuen quickly produced a concept plan including sidewalks and fencing that was acceptable to the GTCA. They had a narrow window between other jobs, and proceeded to fast-track our project with the result that we will now have a much safer pedestrian route on that section of Admirals Road. So thanks again to Peter and Daryl for their quick response and a good looking engineering job!

On a less enthusiastic note on Admirals Road, we are experiencing a huge increase in heavy vehicle traffic, primarily because of the new Trio Ready Mix concrete plant that is now operating in View Royal. Unknown to most of us, View Royal quietly changed their heavy vehicle by-law in December and banned heavy vehicular traffic from the 1A Hwy, forcing all of that traffic along Admirals Road and through our neighbourhood.

We've had logging trucks on that route, and now we are getting concrete trucks and heavy gravel trucks, some with pup trailers, along Admirals Road and into and out of View Royal. Admirals Road has been neglected for many years, and will need serious upgrading to withstand this sort of heavy traffic. Will the Colquitz bridge collapse one day under this increased weight? We need to be very concerned at this development, and Saanich needs to develop a strategy that addresses our concerns.



Dessert & Discussion

On Wednesday, April 14th the GTCA invites you to join us for dessert and discussion (D 'n D) of Gorge area issues. D 'n D will take place at St Martins in the Field Anglican Church on Obed Ave from 7-9pm. We have planned a format that will allow you to get information and give us your opinions on a variety of issues that are ongoing in the neighbourhood. (eg traffic calming, recreation centre and library, Canada Day Picnic, parks and green space, Tillicum Burnside Action Plan).

In recent years we have only held general meetings when a particular issue needed direct local input eg. Waterway Park, Tillicum Burnside Action Plan. We are trying this new informal way of meeting in hopes that it is worth promoting on a regular basis.

We hope you will come along for some D 'n D and tell us what you think. —Harry Lewis

AGM

The AGM will be on Thursday, May 13, 2004 in the Lam Room at Pearkes Rec. Centre at 7:00 pm.



ON PREMISES

Wines
Ciders
Coolers
Ports
Ice Wines

BLACK TIE WINES

Receive **10% OFF** with this ad

(Not to be used in conjunction with other sales.)

380-9463

#102-306 Burnside Road West
Across from Tillicum Mall

...cont'd from page 1

Walking, design and function

Another barrier to walking is the width of the sidewalks. While the newest sidewalks on Maddock and Obed are a standard width and are placed away from the traffic lanes for the most part, there are many others that are not even suitable for a mother with a baby stroller to use.

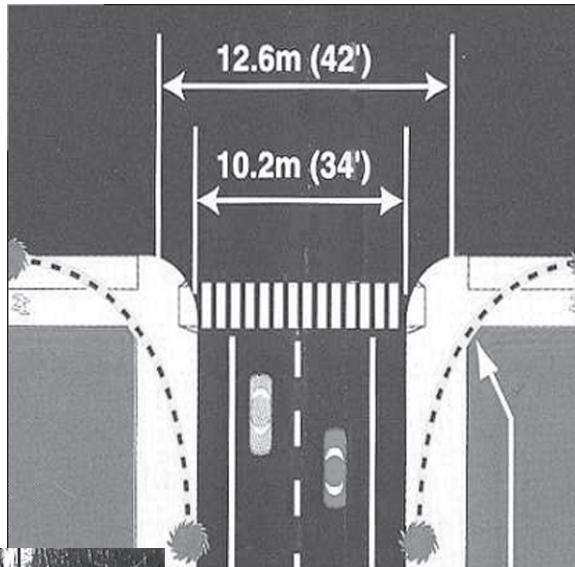

Pedestrian exposure is reduced.



A tight curb design reduces turning speed.

provided us with many insights about how to encourage more walking as a transportation choice.

We learned that encouraging walking is as much about design as anything else. In our community, we have good design so that we can look at nice gardens and water ways. Now we need to apply that quality of design to the rest of the hood!

Walking is the absolute finest way to get to know the neighbourhood and your neighbours. It is that knowledge which helps our community to be healthy and safe, improving everyone's quality of life.

— Rob Wickson

Your community association has been examining walking as a transportation choice for our neighbourhood. Recently, Peter Lagerwey, a transportation planner from Seattle, gave a walkability workshop at Pearkes Recreation Centre that three of the GTCA Board Directors gave a full day of their time to attend. This workshop

"If we surrendered to earth's intelligence we could rise up rooted, like trees." — Rainer Maria Rilke

Still Time to Plant a Tree

If you are interested in taking advantage of the Saanich Tree Planting Program, your order must be placed by the end of May. Your tree will be planted in the fall. Under the program, Saanich will plant a tree on the boulevard in front of your house and maintain it for five years. The cost is only \$75.00.

There are several varieties and sizes to choose, so why not get together with your neighbours and change the landscape of your street. For more information, contact Ray Farmer (382-1122), jpullman@shaw.ca.

Earth Week

April 22 to May 1 is "Earth Week" this year. If anyone in our neighbourhood wants to plan an event this year, you can contact the organizer, Danny Rubin at 361-1876 week@pej.ca. For details of the event in Victoria generally visit pej.ca/week.

Your Neighbourhood Vet Clinic

McKENZIE
 VETERINARY SERVICES
 Dr. Dave Kirby
 Dr. Malcolm Macartney
 Dr. Rona Posen
 Dr. Tin-Wai Kwan

727-2125 Full Hospital Facilities
 24 Hr. Emergency Dogs, Cats, Exotics
 Open 7 days a week Mon. & Thurs. till 8pm
 3888 Carey Road (Corner of Tillicum & Carey)
We Do House Calls Mobile 727-0099

IRWIN INDUSTRIES LTD. (1988)
 327 Harbour Road,
 Victoria, B.C. V9A 3S2
 website: www.irwinvi.com
 E-mail: iivic@inetex.com

- 5" Continuous Gutter Systems
- Gutter Cleaning & Maintenance
- Gutter Protection Systems
- Fascia / Barge / Window Capping
- Vinyl / Aluminum / Hardboard Siding
- Steel Siding / Roofing
- Vinyl Aluminum Soffiting
- Canopies / Patio Covers
- Aluminium Railings

Paul Gerrard Phone: 382-5154
 Fax: 382-5748

202-300 GORGE RD., WEST
 VICTORIA, B.C.
 V9A 1M8
 t: 250-920-7020
 f: 250-920-7099
 c: 250-216-8302
 e: lindalee@llbrougham.ca

LL Brougham Inc.
 CHARTERED ACCOUNTANT

Linda Lee Brougham, CA, CGA, CFP

Bottle Drop
 Beverage Shop

Monday-Saturday 9:30 am-5:30 pm

400 Boleskine & Harriet 475-0040

PAUL WHITNEY
 Real estate professional
 & one of your neighbours...

I have buyers for Gorge area homes!

889-2883 (cell)
 paul_whitney@telus.net
 PEMBERTON HOLMES

The Green Space

Georgia Strait Alliance project

This June and July four members of our local community along with others from the greater Victoria region will be surveying the diversity and population of animals and plants that live on our beaches in the zone between high and low tide. This will be year five in a long-range project to learn about and document who lives at the edge of our sea and how our activities affect them. We will carry out these studies on alternate Saturdays beginning June 5 and concluding July 31. We are in need of additional volunteers to carry out this project. Approximately 3 hours on a Saturday morning or early afternoon are required to complete a study. We expect no prior knowledge just enthusiasm and your time commitment. We prefer it if you can take part in multiple studies especially at first but if you are able to do only a single study during the season that is still acceptable. The beaches are rocky and plant covering slippery so a degree of agility is an asset.

The intertidal zone is the habitat of numerous marine species and is an important indicator of the overall health of the marine environment, so it is crucial that long-term ecological studies be completed. However, there is a lack of reliable data on the inter-

tidal zone and the changes which are occurring with increased human impacts. We are hoping to provide some quality data to fill this gap in our collective knowledge.

An excellent opportunity for you to meet and work with others who enjoy the beach!

To do this we will use scientific methods to gather information which can be pooled with information from other ongoing studies. We work in teams made up of at least 3 veteran members. Newcomers will learn by working beside veterans and performing only those activities such as identifying organisms or recording the observations which they feel they are ready to do.

This is an excellent opportunity for you to meet and work with others who enjoy the beach and share an interest in doing something to preserve and safeguard our natural environment. If you think you might be interested in volunteering get more information by phoning or messaging Judy or Chuck Sigmund. 384-3841 juchu@telus.net We hope to hear from you soon.

A Naturalization Project on the Gorge Waterway

So how does one go about changing a hardened shoreline complete with concrete retaining walls to a naturally functioning waterfront environment? This is the question TLC - The Land Conservancy has posed to the University of Victoria's Coastal Shoreline Restoration Class that started this January. The City of Victoria owns a waterfront property on Selkirk Avenue and registered on title is an agreement that TLC will restore the shoreline environment to its natural condition. The size of the lot is relatively small but the naturalization will help to create better wildlife habitat, add complexity to the intertidal zone, prevent erosion, and create an upland area to support native plants. Once complete, the site will serve as a demonstration site to educate the community on appropriate stewardship practices regarding the waterfront environment. The project will showcase alternatives to a hardened shoreline that individuals can then integrate into their own backyard.

...Naturalization Project

The art of restoring a natural environment necessitates a multi-disciplined approach. The UVic students were fortunate to have experts speak on marine ecosystems, contaminated sites, geomorphology (looking at how the Gorge was formed 10,000 years ago!), legislation surrounding coastal restoration, First Nations concerns, archeology, coastal development, and the role of engineering in our shoreline environment. All of the speakers provided a great deal of knowledge to the class, however, one highlight was the slide show by Dennis Minaker on the history of the Gorge Waterway. But the show didn't stop in the classroom! We took it out to the waterway with two Dragon Boats as Dennis continued his tour of stories and amusing anecdotes surrounding the waterway and its glory days. The stories made quite an impression on the importance and significance of this waterway for Victoria, in the past, and in the future.

A phenomenal amount of information has been provided and gathered and now the students are compiling a Restoration Plan for the site. Stay tuned for the outcome of this course and how you can become involved in this exciting project! Contact Paula Hesje at paula@conservancy.bc.ca or 479-8301 for more information.

Know Any Local Environmental News?

If you know of any environmental news specific to the Gorge-Tillicum area, let us know! E-mail the Green Space coordinator at julia@makeandbelieve.com with a news idea or story. 300 word limit, next deadline June 4th.



Sheila Orr
MLA, Victoria-Hillside

Community Office
815 Bay Street, V8T 1R3
T: 952-4262 F: 952-4488
email: sheila.orr.mla@leg.bc.ca
web: www.sheilaormla.bc.ca

Privileged to serve you

Gorge Canada Day Picnic

It's that time of year again when the Picnic crew is gathering for discussions and planning for this year July 1st event along the Gorge Waterway. To improve upon previous Picnics always seems such a big task and we face it again this year after a wonderful day in 03. There are some new ideas floating around for Picnic #6, but as always we'd love to hear from you, or better still come and join us! An event like this needs 'new legs' from time to time, to match the commitment from 'old hands', so jump into the action on the largest Canada Day event in Victoria. Call Harry Lewis at 384-8460

Of Days Gone By

Dennis Minaker has decided to discontinue his historical articles and photographs on the Gorge neighbourhood. On behalf of Neighbourhood News I'd like to thank Dennis for his contributions over the past few years. Many of us will miss his informative and enjoyable columns which graced our pages as a regular feature. — Harry Lewis

Transitions

Recently our newsletter editor Susan Dunlop informed us that due to the increased demands of her business she would be unable to continue in the position. The spring edition was to be a transition with Susan collaborating with a new editor. This transition was thrown into some disarray recently when Susan was suddenly taken ill. We're happy to report she is recuperating at home now.

Firstly, our thanks and best wishes go to Susan who has helped us produce a newsletter unrivalled by any other community groups. Susan proved to be a cool customer when deadlines were tight and always took great care in producing a quality newsletter, all while maintaining her lovely sense of humour and perspective.

And now we'd like to welcome Melinda Harris as our editor for this edition at least. Melinda has extensive experience in publication and promotion and we look forward to her contributions to Neighbourhood News. Thanks for coming to our rescue Melinda!



At the Centre

G.R. PEARKES RECREATION CENTRE

The Elimination of Intimidation

Have you passed by those glass windows and taken a peak? Have you wondered how the participants became so fit and confident? How did they know which way to sit on those pieces of machinery that remind you of a wild ride in an amusement park! Myself included - I was a weight room window wonderer. How did I conquer this fear, my curiosity? I participated in a weight room orientation. The truth is, our fascination with a weight room all began as an onlooker! Are you wanting to know more?

Our weight room orientations are between 1-1.5 hours in length depending on the number of participants in your session.

Your B.C.R.P.A. (British Columbia Recreation Parks Assoc.) registered weight room instructor will take you through the basic components of a weight room workout. You will learn the basics of a proper warm-up, cardio conditioning (any activity that increases your heart rate), proper use of weight room equipment and machines, free weights, the importance of stretching and how to cool down properly. We create a friendly environment that invites you to express your needs and concerns in regards to becoming a 'member' of our weight room club! Our staff are friendly, non-judgmental, humorous and most importantly - they too were all weight room 'wonderers'! We invite you to go beyond your curiosity!

Register for These Great Classes!

Bike Maintenance

Monday, April 5th, 7:00-9:00pm.

Dog Obedience Classes

Tuesday, April 6 - May 11th, 7:30-8:00pm.

Ballroom Dance - All Levels

Sundays, April 18 - June 27th, 5:45-7:00pm.

Aikido - All Levels

Mon/ Wed, April 12 - May 19, 6:15-7:45pm

Tai Chi - All Levels

Tuesdays, April 27 - Jun 29, 6:30 - 7:30pm

BootCamp drop-in

Wednesdays, 6:35-7:35pm

More Youth Programs at Pearkes!

Cultural Kitchen Workshops (12yrs+)

Learn about other cultures while preparing easy, tasty international dishes (Saturday afternoons, 1-4PM). Cost: \$15.00 each.

Mexican Fiesta April 24th

Exotic Indian Delicacies June 26th

Spring Youth Craft Market

Looking for youth vendors (10+ yrs) to sell their crafty, marketable creations and handicrafts during Youth Week.

Sunday, May 2, 2004 from 11am-5pm at the Community Booth in TillicumMall 3100 Tillicum Road.

Contact Gaileen at 388-6664 for further information.

Registration for Spring Summer starts April 17th, watch for the new Saanich Active Living Guide coming to your door April 14th

Saanich
RECREATION
Sharing
THE Possibilities

WWW.SAANICHRECREATION.CA

Pearkes Recreation Centre
3100 Tillicum Road
Ph: 388-6664 or 24hr Info Line: 475-5576

FACILITY HOURS

January 2nd-April 27th

Mon-Fri 6:30AM - 10:00PM
Sat-Sun 7:00AM - 9:30PM

Stat Holidays

April 9 8:00AM - 4:00PM
April 10, 11 7:00AM - 8:00PM
April 12 8:00AM - 4:00PM